

865-250/450-Ш

Production according to TR 3113-003-15365247-2009

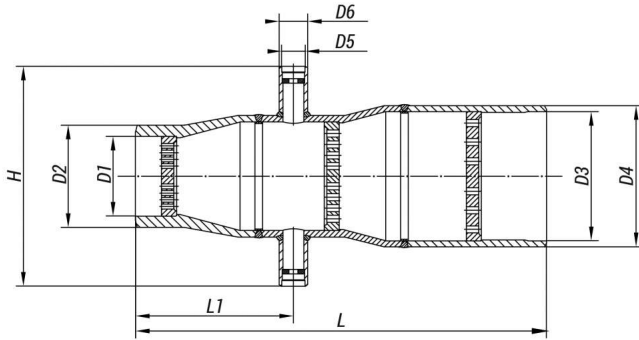

They are directly installed behind the globe and throttle valves of PRS, PRDS and FRPRDS on vertical and horizontal pipeline sections.

Working medium flow direction: from a branch pipe of lesser diameter to a larger one.

Body material:

- steel 12X1MΦ or 15X1M1Φ at the temperatures over 450 °C;
- steel 20, 09Г2С or 15ГС at the temperatures under 450 °C.

Pipeline connection: welded connection.

Specifications

Inlet /Outlet Tp (Tmax), MPa	Inlet /Outlet Pp (PN), MPa	DN, mm	Working Medium	d2, mm	L, mm	L1, mm	H, mm	D1, mm	D2, mm	D3, mm	D4, mm	D5, mm	D6, mm	Full Weight, kg	S1, cm2	S2, cm2	S3, cm2	S4, cm2	S5, cm2	S6, cm2
490/470	12,3/2,0	250	Steam	62	1125	620	650	263	325	424	465	62	76	295,0	174	260	0	0	0	0

Legend

S1, S2, S3, S4, S5, S6 - Gird Passage Area, cm²

The throttle devices of series 863, 865, 891, 950, 1040, 1041 are used as uncontrolled throttling elements of PRS, PRDS and FRPRDS.

The throttle devices DN 100/200 of series 1040 and 1041 are respectively included into the composition of steam-generating plants УПГ 50/60 and УПГ 60/160.

The table demonstrates typical throttle devices. However, the majority of throttle devices is individually designed for specific operation conditions.

Page link:

<https://en.bkzn.ru/catalog/rou-brou-ou-ru-oborudovanie/drosselnye-ustrojstva/865-250450-w/>