

788-400/600-0-03

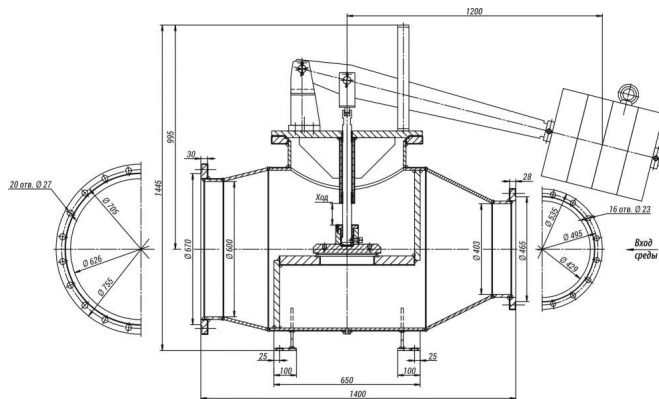

Production according to TR 3740-002-15365247-2004.

Valve body material: carbon steel.

Pipeline connection: flanged connection.

Installation position: on horizontal pipeline sections in the position of the rod upwards in the places convenient for maintenance.

The valve body has foot supports for the valve mounting to the building structure.

Gate sealability: according to class A GOST 9544-2015.

Climatic version: У, УХЛ, Т according to GOST 15150-69.

Placement category: 3 according to GOST 15150-69.

Specifications

DN, mm	PN, MPa	Tmax of the Medium, °C	Body Material, Steel	Working Medium	Operating Stroke, mm	F, cm ²	Maximum Steam Rate, t/h	μ, not less than	Inlet/Outlet Diameter, mm	Designation - display in a group	Designation - display in the product table	Updated	S1, cm ²	S2, cm ²	Torque, N*m
400	0,45	148	20	пар	100	452	55	0,5	400/600	0	0	0	0	0	0

Legend

DN - Nominal Diameter

PN - Nominal Pressure

P - Pressure

Tmax - Maximum Design Temperature

Мкр - Spindle Torque

t - Response time

μ - Fluid Flow Coefficient

h - Valve Stroke

Kv - Throughput Capability

F - Seat Area

ζ - Resistance Coefficient

The pressure safety valve DN 400/600 of series 788 is a direct-acting protective device.

It is installed on pipelines of reduced and cooled steam after the pressure-reducing and desuperheating stations.

Page link:

<https://en.bkzn.ru/catalog/armatura-zashhitnaya/klapany-predoxranitelnye-serii-788/788-400600-0-03/>