

# 950-100/150-Э-01

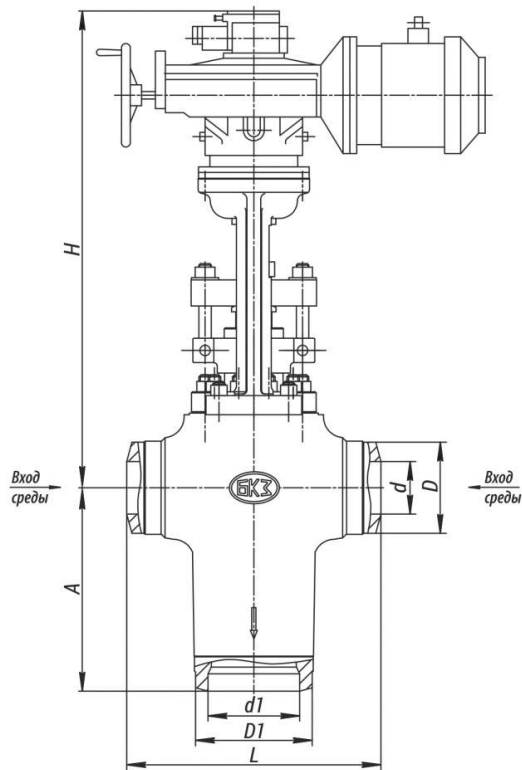

Pipeline connection: welded connection.  
 Maximum pressure differential on the valve: critical.  
 Installation position: on horizontal pipeline sections with the medium direction to the rod through the lateral branch pipes.  
 Climatic version: У, УХЛ, ХЛ, Т according to GOST 15150-69.  
 Placement category: 2, 3 according to GOST 15150-69.  
 The valve control is carried out with the help of a multi-turn built-in electric actuator.

## Specifications

DN, mm	Pp, MPa	Tmax of the Medium, °C	Body Material, Steel	Working Medium	Operating Stroke, mm	Max. Steam Flow at Critical Pressure Differential, t/h	TQ, N·m, maximum torque at spindle plug	Full Stroke Rotation Number	d1, mm	L, mm	Designation of the electric drive	N, kW	t, c.	H, mm	D, mm	D1, mm	d, mm	A, mm	Full Weight, kg	Torque, N·m
100	25	545	15X1 M1Φ	пар	40	120	1110	5	170	600	794-ЭР-0а	3,2	14	1320	172	255	97	450	701	0

### Legend

**DN** - Nominal Diameter  
**PN** - Nominal Pressure  
**P** - Pressure

**Tmax** - Maximum Design Temperature  
**Мкр** - Spindle Torque  
**t** - Response time  
**μ** - Fluid Flow Coefficient

**h** - Valve Stroke  
**Kv** - Throughput Capability  
**F** - Seat Area  
**ζ** - Resistance Coefficient

The throttle globe valves of series 950 serve as controlled throttling devices of FRPRDS, which perform pressure throttling of the passed medium together with throttling devices sequentially installed after the valves.

They are intended for the live steam discharge in case of starting or stopping the power generating unit, in case of steam requirement per a turbine less than the evaporation capacity of the steam generator, excess steam pressure increase in the system and sudden reduction of the turbine load.

**Page link:**

<https://en.bkzn.ru/catalog/armatura-reguliruyushhaya/klapany-zaporno-drosselnye/950-100150-e-01/>