

12c-4-2Э

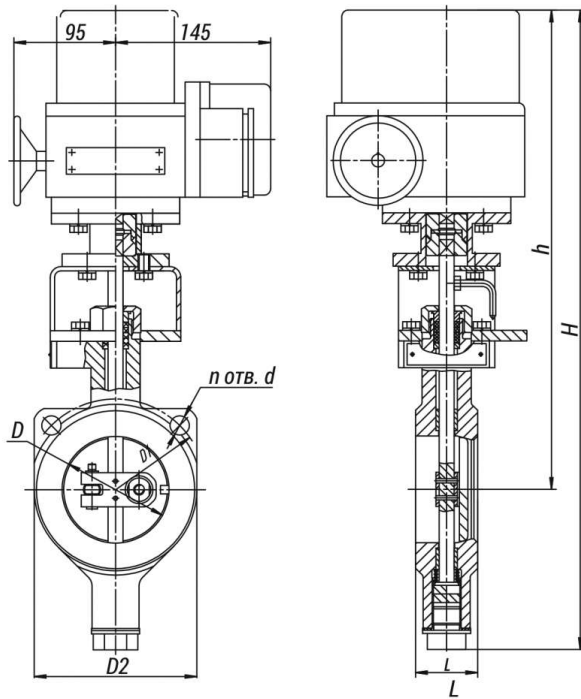

Pipeline connection: welded connection.

The maximum pressure differential on the valve is limited.

Installation position: on horizontal and vertical pipeline sections.

Climatic version: У, УХЛ, ХЛ, Т according to GOST 15150-69.

Placement category: 2, 3 according to GOST 15150-69.

The valves are controlled through a quarter-turn actuator with a current position sensor of single-turn electric actuator (МЭ0) and single-turn electric flanged actuator (МЭ0Ф) types (ABS ZEIM Automation, OJSC, Cheboksary) etc.

Specifications

DN, m	PN, MPa	Tmax of the Medium, °C	Body Material, Steel	Working Medium	F, cm ²	TQ, N·m, maximum torque at spindle plug	Full Stroke Rotation Number	Designation - display in a group	Designation - display in the product table	L, m	Designation of the electric drive	N, kW	t, sec	H, m	h, m	D, m	D1, m	d, m	D2, m	n	Weight without Electric Actuator, kg	Full Weight, kg	Updated	S1, cm ²	S2, cm ²	Torque, N·m
100	0,063	400	09Г2С	Air, gases	54,5	350	0,25	0	0	58	МЭ0Ф-40/25-0,25У-96К	0,11	25	586	438	100	170	18	152	2	13	21	0	0	0	0

Legend

DN - Nominal Diameter
PN - Nominal Pressure
P - Pressure

Tmax - Maximum Design Temperature
Мкp - Spindle Torque
t - Response time
μ - Fluid Flow Coefficient

h - Valve Stroke
Kv - Throughput Capability
F - Seat Area
ζ - Resistance Coefficient

The control valves with butterfly dampers of type 12c are intended for the flow control of water steam, gas and air.

The control is carried out by means of changing the area of passage section between the body and the butterfly damper when turning it. The full opening of the valve corresponds to the lever turning by an angle of 75 from the closed position.

Page link:

<https://en.bkzn.ru/catalog/armatura-reguliruyushhaya/klapany-s-povorotnoj-zaslonkoj-tipa-12s/12s-4-2e/>