

23c-150-1-3

Production according to TR 3740-002-15365247-2004

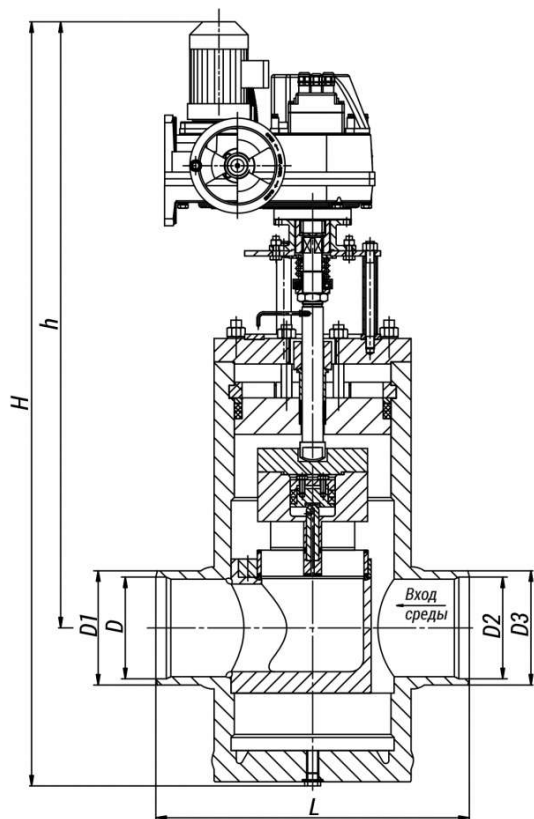

Pipeline connection: welded connection.
Climatic version: У, УХЛ, ХЛ, Т according to GOST 15150-69.

Placement category: 3, 4, 5 according to GOST 15150-69.

Installation position on the pipeline: horizontal, vertical.
 Working medium supply direction: to the seat.
 According to the arrow on the body.

Gate sealability: class IV GOST 9544-2015.

The control is carried out through:

- ☒ built-in electric actuators of single-turn electric flanged actuator (МЭОФ) type manufactured by ABS ZEIM Automation, OJSC, Cheboksary;
- ☒ electric actuators of other manufacturers with standard connection units.

Specifications

DN, m	PN, MPa	Tmax of the Medium, °C	Body Material, Steel	Working Medium	Max. Pressure Differential, MPa	F, cm ²	TQ, N·m, maximum torque at spline plug	Inlet/Outlet Diameter, mm	Designation - display in a group	Designation - display in the product table	L, mm	Designation of the electric drive	N, kW	tx од, c.	H, mm	h, mm	D, mm	D1, mm	D2, mm	D3, mm	Weight without Electric Actuator, kg	Full Weight, kg	Up dated	S1, cm ²	S2, cm ²	Torque, N·m
150	10	450	20	вода-пар	354	119,65	1000	150/150	0	0	600	МЭОФ-1000/25-025У-97К	0,25	25	1465	1162	142	159	142	159	498	540	0	0	0	0

Legend

DN - Nominal
Diameter
PN - Nominal
Pressure
P - Pressure

Tmax - Maximum
Design Temperature
Mкр - Spindle Torque
t - Response time
μ - Fluid Flow Coefficient

h - Valve Stroke
Kv - Throughput Capability
F - Seat Area
ζ - Resistance Coefficient

The pressure-compensated control disc valves DN 80-200 of type 23c are intended for the control of the working medium flow or pressure.

The medium flow through the valve is regulated by means of changing the area of passage section, which is achieved when turning the spool with regard to the seat.

They are not used as shutoff devices.

Page link:

<https://en.bkzn.ru/catalog/armatura-reguliruyushhaya/klapany-razgruzhennye-diskovye-tipa-23s/23s-150-1-e/>